

GE Power



Products & Solutions for the Oil & Gas Industry

GE's Power Conversion Business

gepowerconversion.com

GE's Power Conversion Business

GE's Power Conversion business applies the science and systems of power conversion to help drive the electric transformation of the world's energy infrastructure. Designing and delivering advanced motor, drive and control technologies that evolve today's industrial processes for a cleaner, more productive future.

Contents

Oil & Gas

Challenge and Value	4
Solutions	6
System Integration	10
Key Product Portfolio	12
Drives	14
Motors & Generators	19
Testing Capabilities	25
Services	26



Challenge & GE Value

GE helps to enable reliable, safe and highly efficient processes across Oil & Gas operations by delivering high performance and compact electrical solutions.

Productivity and Operational Efficiency

Space and Weight optimization in offshore projects

Challenge



Unplanned outages from motor failure can cost refineries millions in lost revenue for time offline

For a mid-size LNG facility, the average annual cost of unplanned downtime is estimated at \$150m

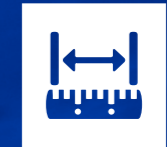

Average project capital expenditure for an offshore project can be between \$5b and \$20b

> Complete stoppage of 1 LNG compressor train can cause lost production worth millions

> Weight adds cost to projects: For every single ton of equipment, three tons of additional support structure is required

> Deepwater projects need specially designed production facilities and large FPSO topsides can exceed 50,000 tons

GE Value

> Our high-power drive train technology can allow up to 48% higher uptime due to design simplicity, fewer parts and extended maintenance intervals

> Integrated solutions can reduce installation and commissioning time by up to 67%

> The integrated compressor line (ICL) solution saves up to 60% in space and footprint compared to conventional compressors

Oil & Gas Solutions

Upstream

Offshore Production

- Fixed-speed motors with low starting current capabilities, direct on line motors and variable-speed drive solutions to power the compressor/pump
- High-speed integrated/standalone gearless solutions
- Power generation and Energy Management Systems (EMS)
- HVDC long distance electrical connection

Subsea

- Subsea gas compression variable-speed solutions
- Subsea pumping variable-speed solutions
- Subsea power solutions (to control, protect and distribute power to the subsea consumers)

FPSO

- Fixed-speed motors with low starting current capabilities, direct on line motors and variable speed drive solutions to power the compressor/pump
- High-speed integrated/standalone gearless solutions
- Power generation and Energy Management Systems (EMS)

Onshore Production

- High-speed integrated/standalone gearless solutions
- Variable-speed drive solutions
- Energy Management Systems (EMS)

Downstream

Refinery

- High-speed integrated/standalone gearless solutions to replace steam turbines
- Low-speed synchronous motors
- Variable-speed drive solutions with a high level of redundancy
- Energy Management Systems (EMS)
- Fully integrated HV/MV/LV electrical package, including turnkey HV substations, e-Houses and SCADA plus protection and control

Petrochemical

- High-speed integrated/standalone gearless solutions to replace steam turbines
- Variable-speed drive solutions with a high level of redundancy
- Energy Management Systems (EMS)
- High-torque induction machines to power hyper compressors LDPE and HDPE applications
- Fully integrated HV/MV/LV electrical package, including turnkey HV substations, e-Houses and SCADA plus protection and control

Midstream

Pipeline/Storage

- High-speed integrated/standalone gearless solutions
- Variable-speed drive solutions
- Fixed-speed induction motors
- Two-pole machines for larger pipelines
- Fully integrated HV/MV/LV electrical package, including turnkey HV substations, e-Houses and SCADA plus protection and control
- SCADA pipeline software for pipeline flow optimization

LNG

- Gas turbine starter/helper for refrigerant compression train
- Fully electric high-power solution for refrigerant compression train
- Variable-speed drive solutions
- Fully integrated HV/MV/LV electrical package, including turnkey HV substations, e-houses and SCADA plus protection and control
- Energy Management Systems (EMS)

Oil & Gas Solutions

GE is helping the oil and gas industry meet the challenges of operating safely and efficiently in an increasingly demanding and regulated environment. Our highly engineered equipment enables you to make well-informed decisions.

Integrated Compressor Line (ICL)

Advanced centrifugal compressor technology with an electric motor driver in a single, completely sealed casing

The ICL, jointly developed with BHGE, a GE Company, is driven by high-speed motor and high-frequency drive technology. The pressurized induction motor includes a laminated rotor with a squirrel cage – a design proven by more than four million operating hours in industry-wide applications.

With Active Magnetic Bearings (AMB) technology, the rotor is levitated by a control system that precisely regulates the rotor spacing to avoid all parts contact and friction. This eliminates the need for lubricant thereby solving the problem of leak-prone lube oil systems used with conventional bearings. The AMB design maintains rotor levitation during starts, normal operation, and stops including emergency shutdowns. Ball bearing back-up allows the machine to stop without damage.

The drive is highly efficient over a very wide operating range, with the same hardware capable of driving the motor at low speeds and all the way up to 300 Hz.

Key features and benefits

- Harmonic study for harmonic mitigation
- Power factor study for generator optimization
- Resonance study for cable optimization
- Power management for high productivity
- DSVC/AFE for high grid stability
- Rotor dynamics study for torque quality
- Component optimization for improved site condition
- VFD/motor/compressor optimization for increased speed range

Unique Expertise in Electrification and Exhaustive Knowledge of LNG Processes

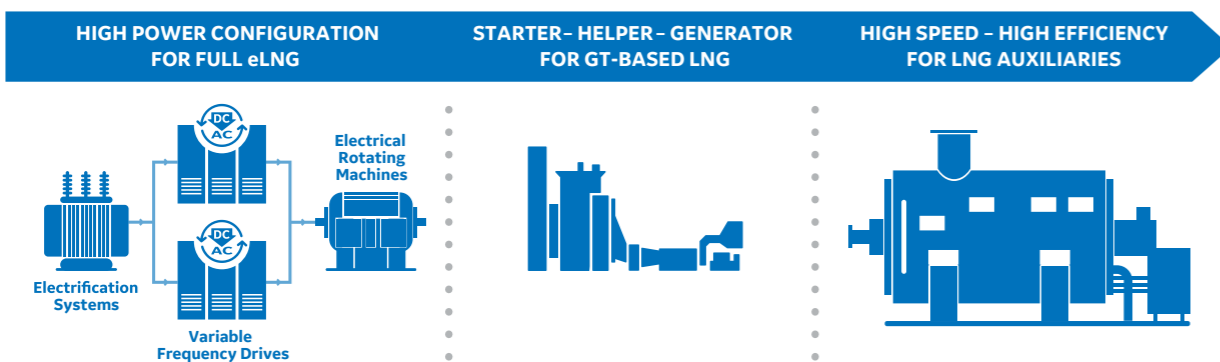

Electrical Equipment and Complete Solutions to Drive Compressors for LNG Applications

We offer a complete, single-source solution – using synchronous or induction motors powered by high-power drives based on IGBT technology – that helps deliver high reliability, availability and efficiency for LNG operators.

We offer a flexible and modular configuration with DFE or AFE enabler for transformer-less configuration fitting all the different LNG electrification needs:

- Small size LNG: soft starter for fixed speed compressors
- Starter-helper and generator for GTs single or double shaft end synchronous or induction motor
- Full electric LNG with direct compressor of the main refrigerant coupling

Steam Turbine Replacement

Electric motors and drive systems for compression process optimization

For processes that don't develop heat or only partially generate steam, like recycle hydrogen, feed gas, and in some instances wet gas applications, or plants located in areas where the power grid is stable, the use of electric motors can represent a better choice vs. steam turbine solutions. The recent advancement of electrification has made it possible and practical for electric motors and drive systems to be an option for powering standalone machines up to 100 MW and integrated ones up to 35 MW.

GE can provide a complete electrical turnkey solution for all compressor OEM types that includes a global guarantee of the motor compressor shaft due to adequate torsional analysis.

A smaller footprint and less necessary auxiliaries make it possible to preserve the plant layout in more constrained environments and allow a smooth plant integration, resulting in savings for the associated infrastructure cost. GE's Variable-Speed Drive Systems (VSDS) feature a unique combination of Voltage Source Inverter (VSI) and a high-speed motor to help increase reliability and availability of your systems

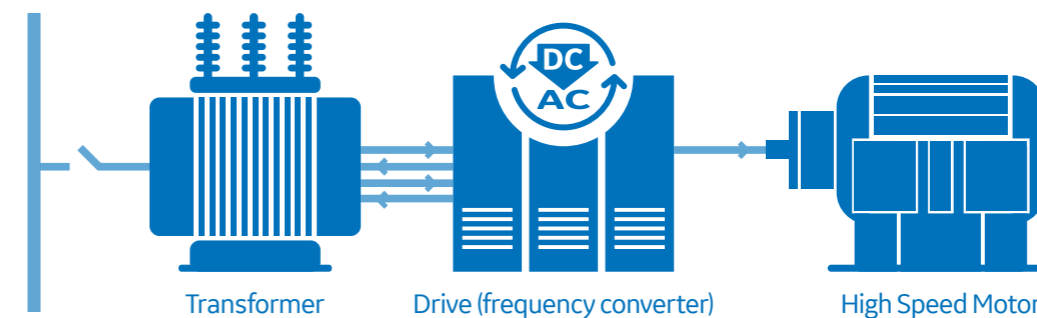

System Integration

We provide a full suite of integrated electrical and power data management solutions to help you extract, deliver and process oil and gas more effectively.

System Network Optimization Capabilities: Single Line Diagram Study and Optimization

From power generation through HV, MV and LV distribution to load package, we have extensive capability and experience in network simulation and calculation. This includes:

- Harmonic study for harmonic mitigation
- Rotor dynamics study for torque quality
- Power factor study for generator optimization
- Component optimization for improved site conditions
- Resonance study for cable optimization
- VFD/motor/compressor optimization for an increased speed range
- Power management for high productivity
- DSVC/AFE for high grid stability

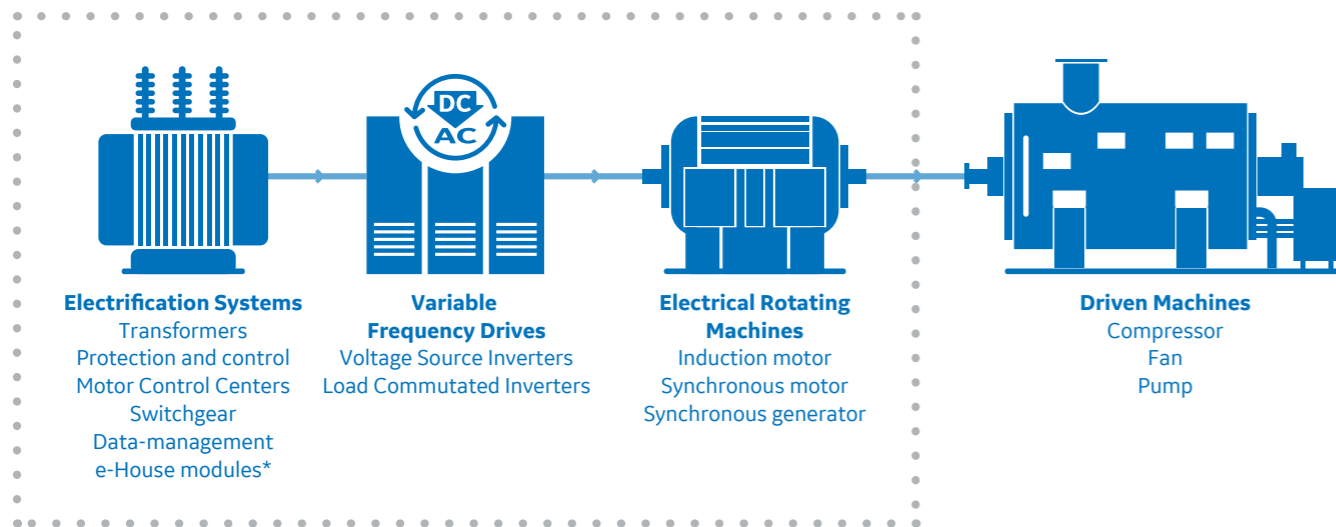

Containerized e-House Solutions

e-Houses or shelters are pre-fabricated modular structures that protect critical power and electrical equipment. Designed for both on and offshore installations, and suitable for all conditions (both hazardous and non-hazardous), e-House modules are particularly beneficial when project space, on-site access or build time is limited. They're also useful in remote locations or when pre-existing structures are unavailable.

Optimizing space and design means faster delivery and installation times plus cost savings on labor. It also simplifies projects and reduces risk.



Power Management System

GE's Power Management System (PMS) provides real-time automation for managing the electrical power availability of industrial plants, minimizing both production losses and safety concerns. Acting as an 'anti blackout' system for islanded plants (FLNG, FPSO and platform), as well as those connected to non-reliable grids, our PMS helps to ensure optimal load balancing at all times, under any circumstances.

PMS is a hot redundant and integrated system that fully manages:

- Power generation coordination with load sharing between running generators – even if heterogeneous (for example: gas turbine, diesel, waste heat recovery unit)
- Power distribution and control with a high-speed load shedding response time – regardless of load number and location
- Supervision and data logging with real-time handling for troubleshooting analysis efficiency
- The communication gateway between all external interface devices
- Reducing Mean Time to Repair (MTTR) in case of electrical device failure

Real-Time Electrical Power Availability

High Performance

- Fast load shedding < 60 ms/all automation fcts < 60ms/Stamping at source 1ms
- Proven full hot standby redundancy
- Time stamping at source, 1 ms/RT handling
- Self-healing networks at segregated data flux

Open-Ended and Modular Architecture

- Ability to communicate with main brand devices
- Decentralized while maintaining performance
- Synchronizing system of energized bus-bars
- Simulator unit

Electrical Power Generation

- Grid
- Turbine Generator
- Diesel Generator

Electrical Power Distribution

- Grid
- Turbine Generator
- Diesel Generator

Control & Safety

- Fire & Gas System
- Process Control System

Motor Control

- Motor & Control Center



Oil & Gas Key Product Portfolio

Power Electronics

Core components of electrical VSDS. These include Voltage Source Inverters (VSI), and IGBT-based and Load Commuted Inverters (LCI) using thyristor technologies.

Models

- MV6 Series
- MV7 Series
- SD7 Series

Technical Capabilities

- Output power: 0.25–120 MW
- Output voltage: up to 13.8 kV
- Output frequency: up to 300 Hz
- Input frequency: 50 or 60 Hz \pm 5%



Electric Motors

A full range of solutions for pump and compressor applications, both onshore and offshore.

Models

- Induction motors
- Synchronous motors
- High-speed motors (both integrated and standalone)

Technical Capabilities

- Speed: up to 20,000 rpm
- Power: up to 80 MW
- Voltage: up to 13.8 kV
- Hazardous zones



Generators

Setting the standard in generator manufacturing for over 130 years.

Models

- Turbo generators (gearless)
- Synchronous gas and steam turbine-driven
- Reciprocating engine-driven

Technical Capabilities

- Speed: Two to 22 pole range
- Power: 2,500–80,000 kVA
- Voltage: up to 22 kV
- Frequency: 50 or 60 Hz
- Hazardous zones

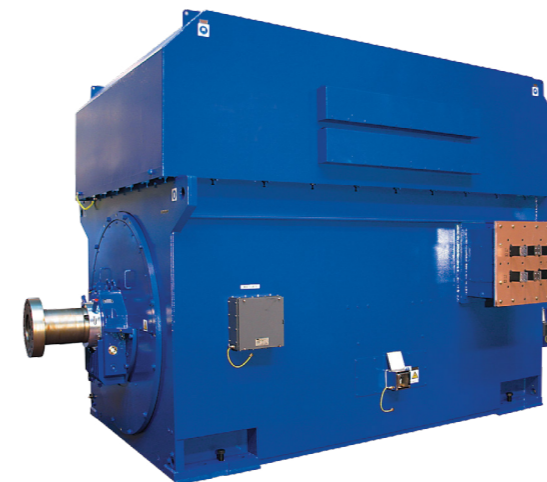

Automation and Controls

A comprehensive suite of advanced protection, control, automation and communications designed for harsh environments. This enables customers to optimize application capability and cost – helping to generate new revenue sources.

Functionalities

- Motor management and control
- Protection and automation
- Wired and wireless communications
- Industrial internet controls
- Edge analytics and fleet data to optimize operations
- Centralized deployment of apps and firmware upgrades
- Remote monitoring and diagnostics



Medium Voltage Variable-Speed Drive Systems (VSDS)

High-Quality Product Lines

GE combines cutting-edge power electronics technology and decades of process expertise in our medium Voltage Source Inverters (VSI) portfolio.

Our Variable-Speed Drives Systems (VSDS) are used for a wide range of industrial applications – notably where energy efficiency, reliability and safety are key customer expectations.

Whatever our customers' industry setting – onshore and offshore oil & gas, renewables, power generation, marine propulsion, water, metals, or mining – we provide solutions engineered to meet the most demanding requirements. For example, we can address power cycling, low-speed application, power range, harmonic constraints or precise torque control.

Product Range

MV Drives Product Map

Our MV drive family is composed of VSI and Load Commutated Inverters (LCI). It offers a wide power range at various voltages, covering a variety of applications.

GE Advantage

- One of the industry's highest power densities, up to 1.4 MVA/m³ for the water-cooled range
- Outstanding efficiency, up to 99.1% for DFE applications
- High reliability thanks to low component count
- Installed base: 15 GW+, 1,700+ units

MV6 Medium Voltage Drives

Leading Next-Generation Technology

MV6 series VFD is one of the most versatile medium voltage drives on the market, with configurations covering a voltage range of 4.16 kV to 6.6 kV and power range of 210 kW to 6 MW. It's all based on GE's extensive experience in general industry and mission-critical applications.

You can configure MV6 VFD as Diode Front End (DFE) with an integral transformer in two-quadrant operations, re-generative Active Front End (AFE) with a transformer in four-quadrant operations, or a transformerless AFE using a common set of building blocks.

MV6 series VFD is suitable for worldwide applications and is certified to IEC 61800-3/4/5, IEEE 519, UL 347a, CSA C22.2, IEEE 693 and GOST.

Key Features and Benefits

- Bumpless fault tolerance at power device level
- Ease of system integration and grid friendly
- Modern industry design for safety and style
- Ease of integration with e-houses
- Friendly user interface and rich control features
- Quick and easy installation
- High availability
- High efficiency and low losses



	Ratings
Output power	210–3,000 kW (up to 6,000 kW on request)
Output voltage	4.16, 6, 6.6 kV
Output frequency	0–75 Hz
Input voltage	DFE: 4.16 up to 24 kV AFE transformerless: 4.16, 6.0, 6.6 kV
Input frequency	50 Hz, 60 Hz
Cooling	Air-cooled

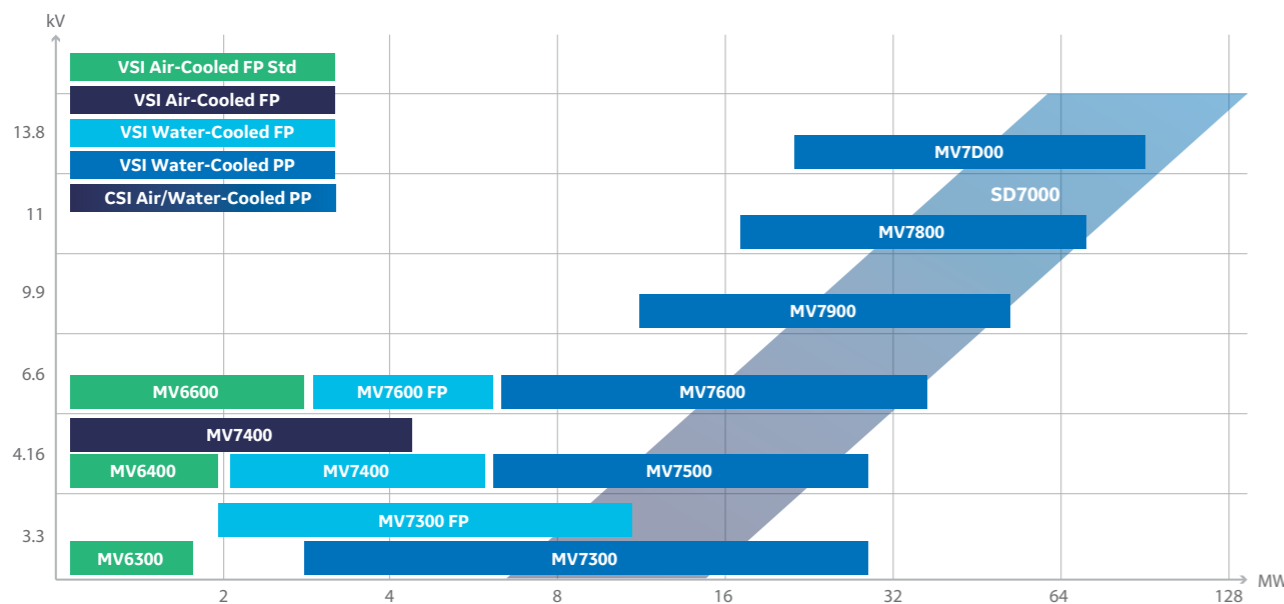

MV7000 Medium Voltage Drives

Our drives can substantially improve the quality and efficiency of your process or production. GE's MV7000 drive technology delivers efficient and flexible control of electric power to a wide range of equipment. The drives can feed both induction and synchronous machines with high-performance vector control across all speed ranges. For multiple applications, with both motoring and regenerating drives, a common DC link fed by a single active front end can reduce the overall equipment cost and footprint.

Key Features and Benefits

- **Power quality:** Low harmonics and a high power factor help minimize the effect on the supply network
- **Energy optimization:** PWM active front end enables regeneration of the energy to the network
- **High efficiency:** Up to 99% performance
- **Reliability:** With press-pack IEGT technology, fuseless protection and a low component count, MV7000 offers longer life expectancy – even under load cycling
- **Power density:** Up to 1.1 MVA/m³ for the complete drive
- **Redundancy:** Secured continuous conduction of the PPI in failure mode
- **Safety:** Case rupture and arc ignition-free due to pressed contacts and no wire bonding
- **High efficiency:** Thanks to low losses



Key Features

- **Air-cooled (AC):** Easy installation and maintenance
- **Water-cooled (WC):** Compact and reduced heat losses through air
- **HV Flat pack IGBT:**
 - HV flat pack integrated components
 - Very compact, especially in lower power range
 - Low part count for high reliability
- **HV Press Pack IGBT:**
 - High robustness for demanding systems (for example, low speed or cycling)
 - Low part count
 - Real N+1 hot redundancy thanks to GE's specific expertise on press pack IGBT
- **Multi-level configuration:**
 - Reduced stress on motors
 - Simplified filters

MV7000 Press Pack (PP)

- Three- or five-level inverters
- HV press pack IGBT
- Water-cooled

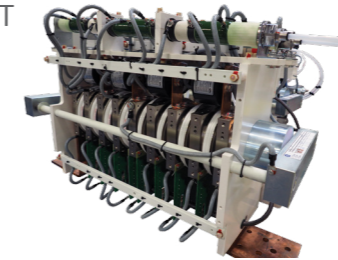

VFD ratings

Output power	3–81 MW
Output voltage	up to 13.8 kV
Output frequency	15–90 Hz, 0 to 15 Hz and 90 to 300 Hz on request
Input voltage	3–13.8 kV ±10% for AFE Txless, 3–650 kV with transformer
Input frequency	50 or 60 Hz ±5%
Auxiliary voltage	3 phase, 400 V, 440 V, 480 V, or 600 V; 50/60 Hz 1 phase, 110 V, 230 V, 50/60 Hz

Common Characteristics

Power Quality

Line side converter	DFE 12 to 36-pulse / AFE IGBT 6-pulse
Load side inverter	3- or 5-level VSI; IGBTs
VFD system efficiency	Up to 99%
Power factor	>0.96 (DFE) / 1 (AFE)
Input harmonics	IEEE 519 compliant

Energy Storage

DC link	Self-healing, long life, film capacitors
---------	--

VFD Control

Mode of operation	Four-quadrant
Mode of control	Flux vector/without encoder/induction motor & synchronous (option)
Analog input/output	(3) inputs/(3) outputs +/-10 Vdc or 4-20 mA standard
Digital input/output	(6) inputs/(6) outputs standard
Speed regulation	<0.5% without encoder and <0.1% with encoder
LAN interface	Standard: Profinet, Modbus, Ethercat, IEC618150 Optional: profibus, devicenet, EGD
Protective functions	Over-current, current limit, over and under-voltage, motor stall

MV7000 Flat Pack (FP)

- Three-level inverters
- HV flat pack IGBT
- Air- or water-cooled

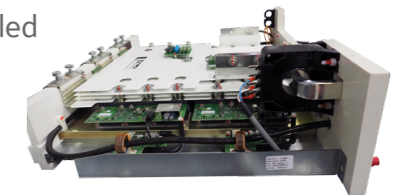

VFD ratings

Output power	0.7–10 MW
Output voltage	3.3 up to 6.6 kV
Output frequency	15–90 Hz, 0–15 Hz and 90–300 Hz on request
Input voltage	3 to 6.6 kV ±10% Txless, 3–650 kV with transformer
Input frequency	50 or 60 Hz ±5%
Auxiliary voltage	3 phase, 400 V, 440 V, 480 V, or 600 V; 50/60 Hz 1 phase, 110 V, 230 V, 50/60 Hz

Environment and Enclosure

Enclosure	IP31, standard, IP33, IP44, option, others on request
Ambient/elevation	0–45°C/1,000m above sea level; higher with de-rating
Insulation coordination	Pollution degree 2 per EN 61800-5-1 and EN 50178

Industry Standards

Standards	IEC 61800-3, IEC 61800-4, IEC 61800-5, IEC 60068-2-31 (vibration) Qualification to industry-specific standards available
-----------	---

SD7000 Medium Voltage Drives

Next-Generation Technology

GE's SD7000 medium voltage drive is designed for high power and speed environments. It controls the power in loads where high performance is required, such as large compressors for gas injection, LNG plants and steam-crackers.

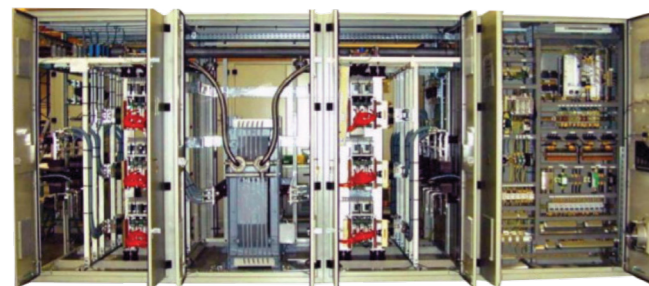

Key Features and Benefits

- Flexible design adaptable to any rating, frequency and cooling configuration
- Control redundancy
- N+1 configuration for increased reliability and availability
- Soft motor start configuration
- Perfect fit for customers requiring new installations or retrofit of existing drives
- Increased reliability in case of control default

Ratings

Power	3 to 100 MW
Voltage	1.5 to 15.75 kV
Frequency	Up to 110 Hz
Cooling	Air- or water-cooled

Two Main Configurations for Soft Starters and Variable Speed Drive

Network side arrangement	Machine side arrangement	Main Application
12 pulses	12 pulses... requires double starter motor	Mainly used for variable-speed drive 12/12 cross connection... limit voltage constraints to ground... enabling longer life duration
12 pulses	6 pulses	Mainly used for soft-starter Step-up transformer allows to reduce voltage on drive... lower number of thyristors For higher output, drive sized to full voltage... no need of step-up transformer Used as well for variable-speed drives in low power and high voltage

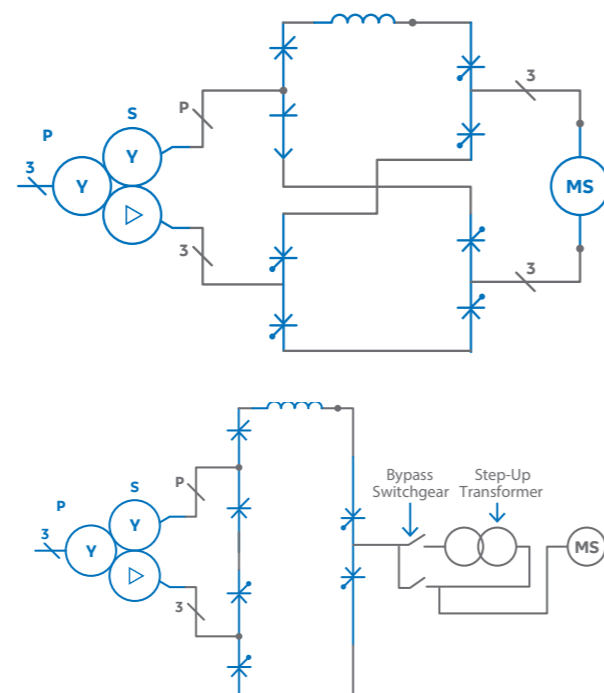

Motors and Generators Overview

GE has set the standard in manufacturing rotating machines for over 130 years and continues to deliver innovative mechanical power solutions worldwide. Our rotating machines are designed to operate efficiently and reliably in challenging and severe environments where ease of maintenance is critical.

Motor Range

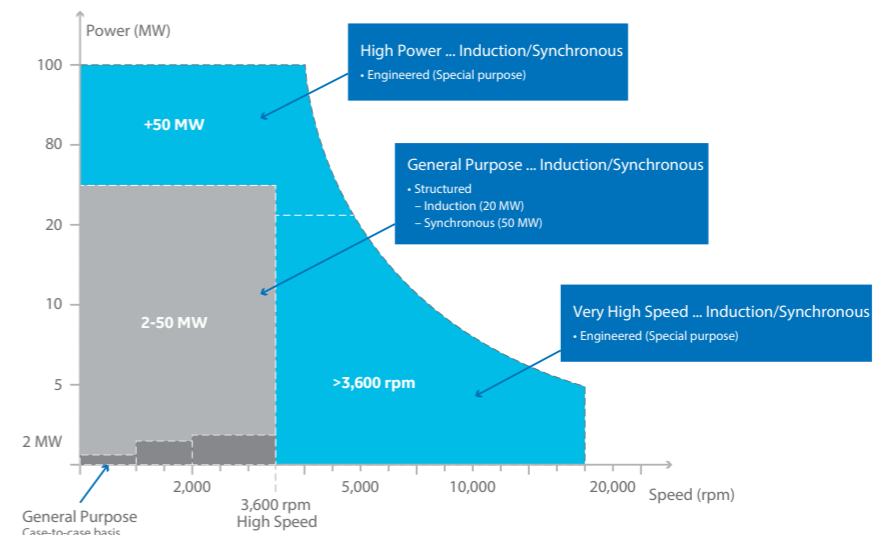

Generator Range

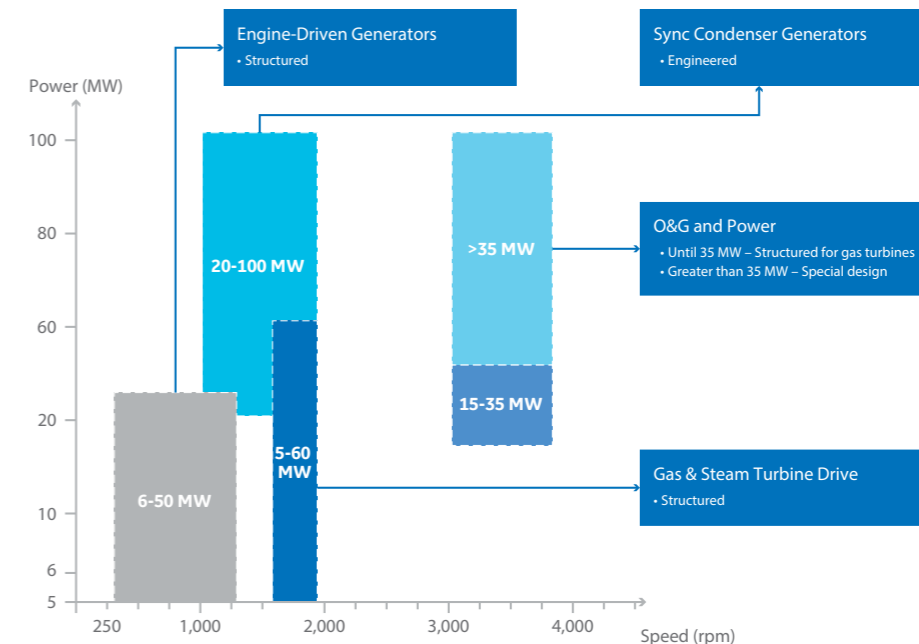

Induction Motors

Compact But Powerful

GE's induction machines provide the highest power density in their class. What's more, the innovative compact frame upgrade to our well-established legacy motor line doesn't compromise on efficiency or reliability.

When Space Matters Most

With a lower frame size than conventional induction motors, this new and compact design translates to space savings and lower weight. This is essential both for onshore and offshore applications where space is at a premium and when platforms require reduced weight motors.

Ratings	
Frame Size	400 to 1,400
Poles	2 to 30
Frequency	50 Hz, 60 Hz, VFD
Cooling	TEWAC, TEAAC, WP11, WPI
Power	2 to 30 MW eq. 4 poles
Voltages	3.3 to 13.8 kV

Helping to Maximize Customer Outcomes

- Reduce operating expenses with longer durability and lower vibration
- Cut capital expenditure with lighter machines that require fewer foundations and associated costs
- Lower energy consumption from machines that are also safer

Key Features and Benefits

- World-class compact design
- High efficiency
- Low noise
- Reduced weight
- Proven design with innovative components
- State-of-the-art manufacturing equipment
- Test facility up to 40 MW (upon request)

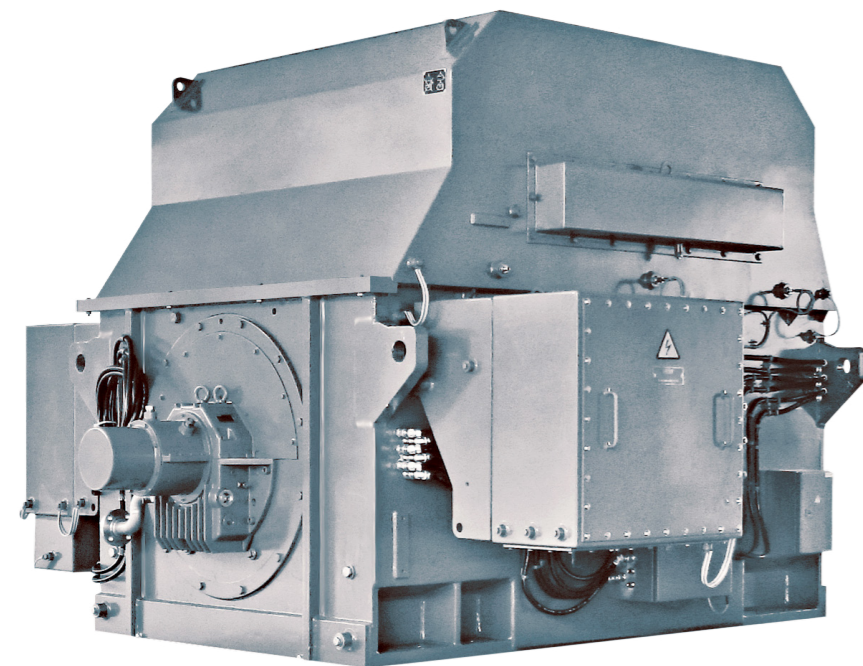

- Applications**
- Reciprocating compressors
 - Centrifugal compressors
 - Pumps

Synchronous Motors

GE offers a full range of horizontal and vertical synchronous motors. These range from direct-drive high-torque density designs (at speeds as low as 20 rpm) to turbo-type motors for compressor applications.

Synchronous Motor Rotor Platforms

- Salient pole rotors
- Two-pole turbo rotor
- Wound rotor

Key Benefits

- High reliability
- Greater efficiency
- Reduced operating expenses
- Less maintenance
- Smooth start-up

We can rapidly adapt our standard product platforms to cater for most applications or proposed starting methods including:

- Fixed-speed started by asynchronous means – for example direct-on-line, series reactor, capacitor, reactor/capacitor or auto-transformer (single or multi-stage)
- Fixed-speed started by pony motor, electronic soft starter or mechanical gear system (i.e. carryable speed planetary gear)
- Variable-speed drive system controlled

Ratings	
Frame Size	900 and above
Poles	2, 4, 6 and above
Frequency	50 Hz, 60 Hz, VFD
Cooling	TEWAC, TEAAC
Power	5 to 100 MW eq. 4 poles
Voltage	3.3 to 13.8 kV

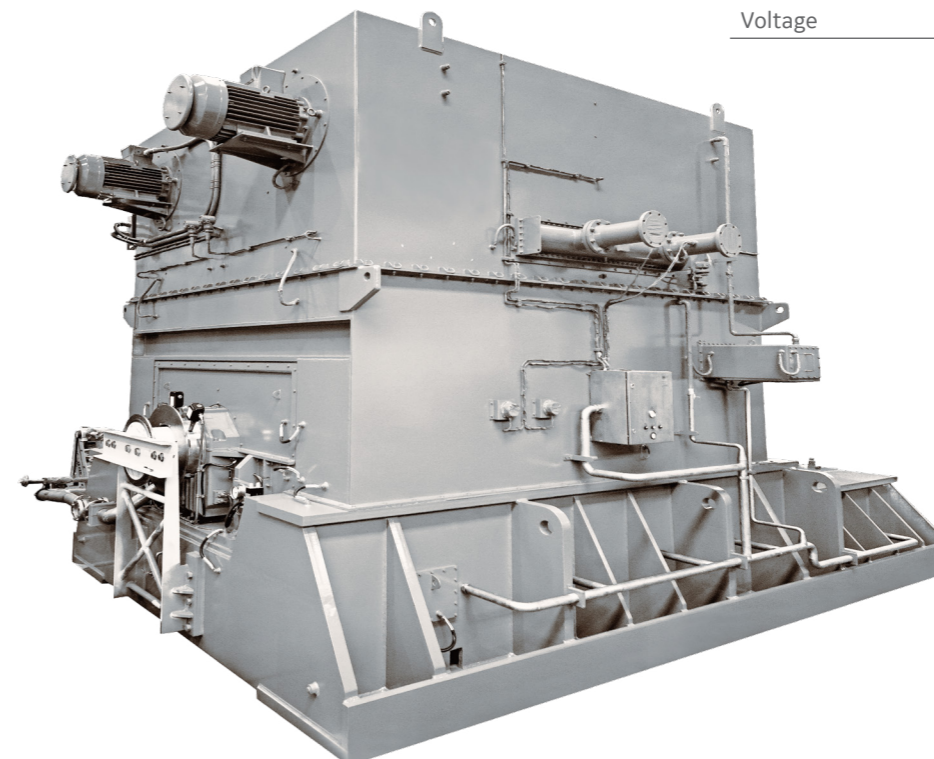

- Applications**
- Reciprocating compressors
 - Centrifugal compressors
 - Pumps

Synchronous Generators

GE has been a world leader in generator manufacture for over 130 years. Having created and implemented some of the first large-scale electrical generators, today we continue to innovate and deliver global power solutions.

Reducing LCOE With High Efficiency

Our generators are designed and built to operate reliably in challenging conditions and severe environments – especially where ease of maintenance is critical. We help to reduce LCOE through:

- High electrical efficiency across the full power range
- Efficient systems solutions incorporating our range of full and partial power converters
- Using components proven in diverse industries
- Ease of maintenance enabling lower operating costs
- Noise levels as low as 77 dba (achievable in closed type machines with operating speeds of up to 1,200 rpm) that help to reduce cost and environmental impact

Key Benefits

- 98%+ efficiency – helping to reduce running costs
- Modular approach – reducing initial investment costs and allowing design flexibility
- High availability and reliability – increasing revenue and reducing risk

Ratings

Output range	5,000 to 75,000 kVA (up to 60 MW 0.8 p.f)
Voltage	up to 13.8 kV and above
Frequency	50 Hz or 60 Hz
Cooling	Air or water cooled

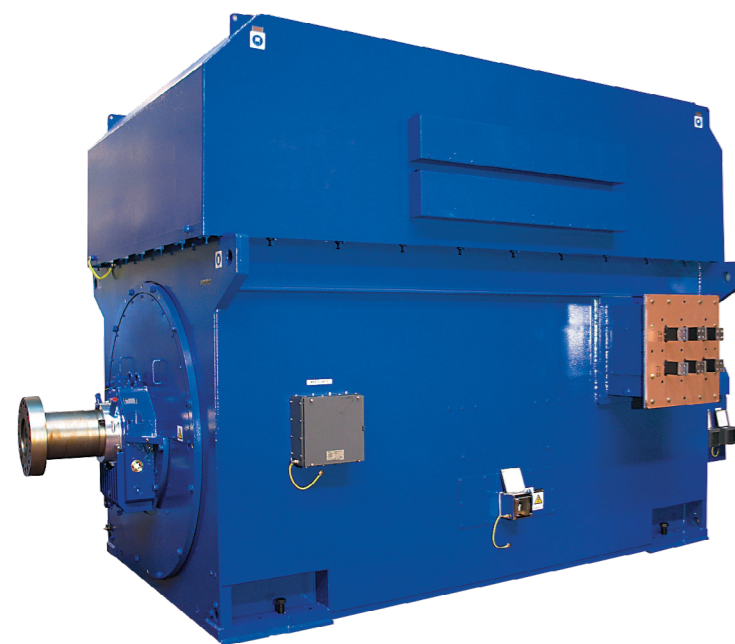

Applications

- Gas/steam turbine-driven
- Diesel/gas engine-driven
- Prime and standby power
- Peaking
- Multi-pole generators for FPSO

High-Speed Induction Motors up to 100 MW

With the growing electrification of many industries around the world, Electric Motor Driven (EMD) solutions are now increasing in power and speed. This is creating new opportunities across multiple applications. Large EMD systems traditionally included large Load-Commutated Inverter (LCI) drives and synchronous motors. However, several innovative breakthroughs, such as the introduction of large power Voltage-Source Inverter (VSI) drives, have improved these configurations. GE's Power Conversion business has delivered further layers of innovation, including high-speed induction motors of up to 100 MW.

Key Benefits¹

Improved Network Stability and Grid Interaction

- Low harmonics content, no network filter required
- No risk of inter-harmonics
- Easy management of the network power factor, even in case of network configuration change

Simplified Compressor Configuration

- Larger speed range and higher Maximum Continuous Speed (MCS) mean greater flexibility in compressor design, improved efficiency and smaller units
- Reduced torque ripple at shaft level

More Efficient Process

- Higher speed and larger range for various applications, such as test benches
- No need for a separation margin with network frequency, thanks to the absence of inter-harmonics
- Low vibration, stable when passing through the first critical speed, simpler rotor, reduced number of critical speeds (no exciter)
- Higher reliability and availability (up to +48% uptime) due to the simplicity of the rotor (non-insulated squirrel cage) and motor compactness

Reduced CAPEX

- Reduced filtering for high-power applications
- Smaller compressor
- Smaller motor with less equipment (for example, there are 10 times fewer rotating parts on the induction full laminated rotor compared to a synchronous rotor)
- Reduced size and lighter supporting structure needed as the induction motor is more compact: smaller footprint (-30%), less weight (-33%)

Reduced OPEX

- Higher drive-motor-compressor system efficiency, saving 1% on energy consumption. For example, it can be evaluated at \$2.8m for an 80 MW machine running full-time for five years
- Better power-factor management and lower operating energy costs
- Less maintenance and fewer spare parts required owing to the simplicity of the induction motor

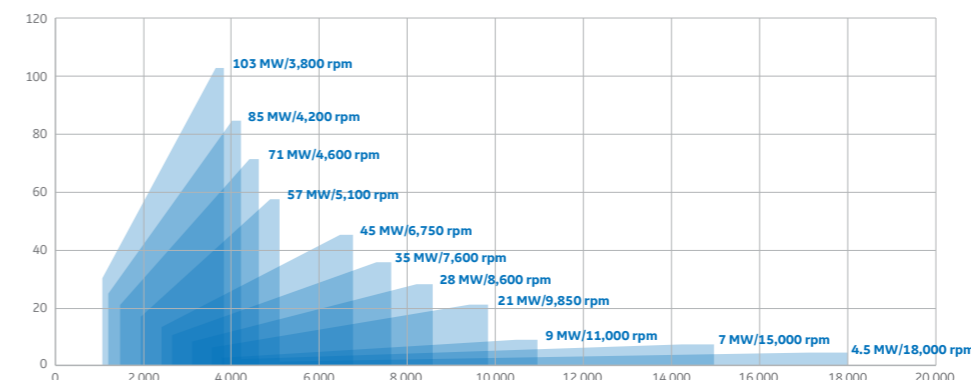

Applications

- Centrifugal compressors
- Pumps

¹ Comparison between traditional synchronous motors fed by LCI and GE's new turbo induction motors fed by VSI.

80 MW High-Speed Induction Motor

Proven Technology

In 2018, GE tested the world's largest induction motor for the LNG industry at 80 MW.



Key Features

- Power: 80 MW
- Speed: 2,500 to 4,000 rpm
- Voltage: 11 kV
- Efficiency: 98.1%
- Weight: 150 tons (330,000 lbs)
- Footprint 4.5 x 6 m (15 x 20 ft)
- Cooling: water-cooled with auxiliary motor fan
- Two oil-lubricated sleeve bearings
- Squirrel cage laminated rotor
- No exciter needed
- Low noise < 90 dBA for such impressive power and speed
- Rotor vibrations < 38 µm peak-peak up to 4,800 rpm overspeed
- Endurance: eight hours at critical speed with a very stable rotor

Testing Capabilities and Certification

We have the capacity to test all equipment at our manufacturing sites before we deliver it to you.

Our Solution

- Full load capability up to 18 MW
- Frequency from 5 Hz up to 300 Hz
- 40 MW loading induction machine
- Alternative method on induction forced cooled motors up to 50 MW
- Full load combined test up to 40 MW: transformer + drive + motor in back-to-back configuration (on request)
- Online data acquisition system
- Electronic database and reports
- Routine tests
- Type tests

Certifications

We can provide certification to the following standards:

- IEC60079 Exp Ex nA
- IEC60034
- Ex d Exe
- API541/546
- Atex (on request)
- IECEX
- Marine class rules
- Ice class
- UL
- Country-specific certifications, like CSA for Canada, BASEEFA for Europe, CU-TR Ex (GOST) for Russia, KOSHA for Korea, INMETRO for Brazil, RETIE for Columbia

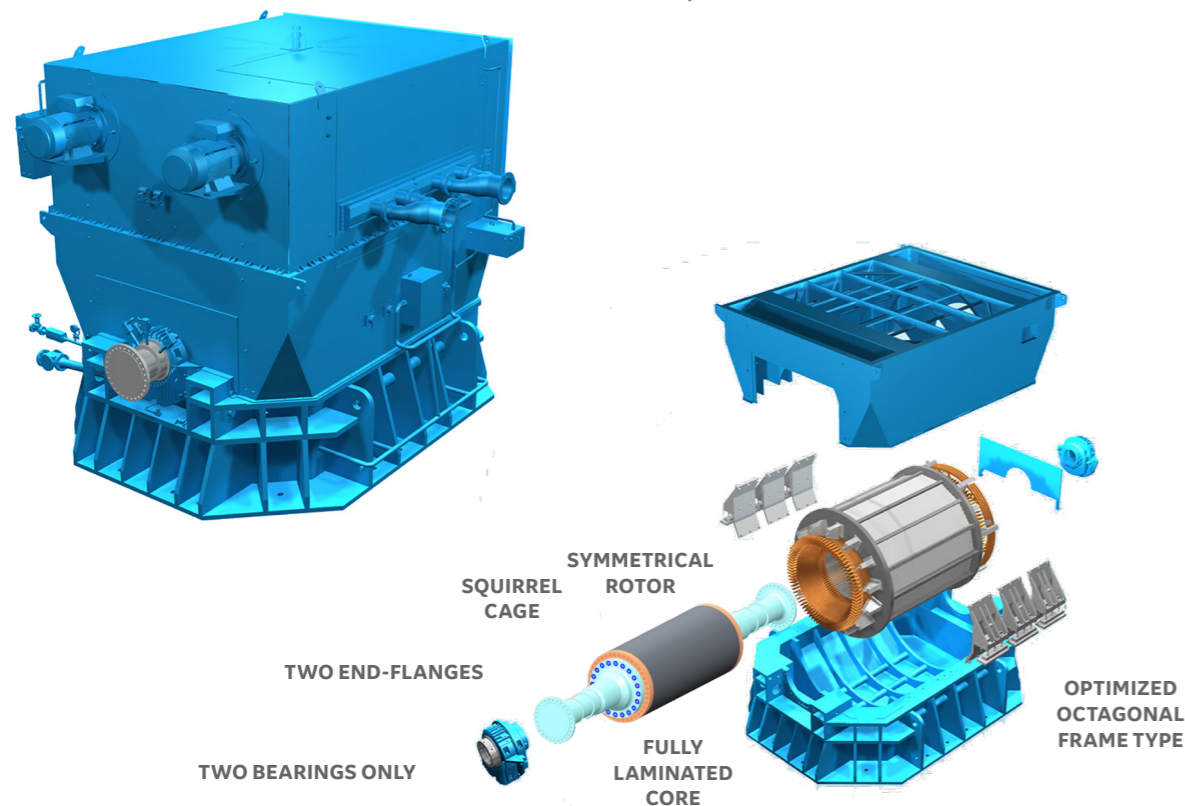

Services Offering

Meeting the Needs of Your Operational Model

GE offers customized services to meet the needs of individual operational and maintenance models – from daily operation, routine and scheduled maintenance to outage services. These include:

- Remote monitoring and diagnostics
- Maintenance
- Spare parts and obsolescence management
- Warranty extensions
- Response-time guarantees
- Availability guarantees as risk sharing mechanisms

Fleet Data Analytics and Predictive Maintenance

Through our advanced digital platforms, GE delivers expert on-site and remote round-the-clock support and emergency interventions—all customized to meet unique customer requirements.

Multi-Year and Local Support

GE offers both on-demand services and multi-year contracts with a range of options, from “Keep me running” to “Partnership.” We have field service engineers operating in over 170 countries – GE has the capability to support our customers wherever they may be.

Enhancing Energy Harvest Across Project Life Cycles

Our services help to support continuous plant operation, driving higher energy yields and return on investment throughout the life cycle. For equipment benefiting from GE multi-year service agreements, product availability and uptime can also be significantly higher.

Reducing Risk, Enhancing Productivity

GE services cover a broad range of activities necessary to protect assets and keep critical processes running. This helps to reduce risk and enhance productivity while letting the owner/operator concentrate on their core business.

Drives Health Check

Minimizing the Risk of Unplanned Outages

We know that any unplanned outage comes with significant costs. We also understand that good maintenance and equipment inspections reduce the risk of outages and enhance reliability. However, we recognize that you don't want to pay for any more maintenance than is necessary.

GE has designed, built and commissioned thousands of drives and we continue to support many of them as part of a planned maintenance cycle. Plus, when customers have an unplanned outage, we help them get back up and running as quickly as possible. That's why, as an OEM with over 125 years of engineering expertise, we're your partner of choice for preventive MV drive maintenance services.

Preventive Maintenance Programs

Regular maintenance ensures efficient drive operation and reduces failure risk. We offer structured inspections and planned maintenance programs geared to the operating environment, which help to minimize costs.

We offer two types of preventive maintenance programs:

- **Preventive Performance Maintenance** (annual) – includes basic visual inspections and drive performance checks.
- **Preventive Major Maintenance** (once every five to ten years) – includes advanced visual inspections, drive performance checks of drives and systematic component replacement.

Preventive Maintenance Program Features

GE's preventive maintenance programs are tailored to suit your needs. Our field service experts carry out inspections and performance checks on drives quickly and effectively, when it's convenient for you. We'll also work with you to understand historic maintenance, environmental conditions, budget and operational constraints, and business imperatives.

During the preventive maintenance service, we:

- **Perform and record preventive actions** – according to a prescribed schedule of appropriate checks
- **Identify safety-critical issues** – bringing them to your attention immediately and proposing resolutions.
- **Prioritize the dispatch of parts needed to resolve any such issues** – if necessary, the field service engineer will remain on or return to site to supervise
- **Identify operational-critical issues** – bringing any deterioration in performance or critical items affecting reliability to your attention and recording them in the maintenance report
- **Audit and record** an inventory of spare parts

After the preventive maintenance service, we issue a maintenance report and recommend:

- **Critical spare parts** – providing a list of those you should consider holding
- **Replacement parts** – suggesting obsolete parts which you may wish to plan to replace
- **Upgrade packages** – appropriate for your equipment and circumstances

MV Drives Control Modernization and Upgrade

If you currently rely on vintage MV drive controls, you can't ignore the risk of obsolescence. However, you can avoid it. A reliable and cost-effective upgrade can save you the time and expense of a complete systems replacement.

This simple upgrade will modernize your controls and data interfaces, substantially improving control capabilities and performance. Extensive diagnostics and self-testing can make systems easier to maintain, with GE's outstanding drive services helping you get the greatest possible value from your MV drives' controls.

The external control interface—GE's P80i Control System toolbox – is widely considered as one of the best tools for configuring, troubleshooting and maintaining legacy MV7000 drives and controls.

Features and Benefits

- Experts that fully understand your industry and will match our drive features to meet your specific requirements
- Consistent and cost-effective project execution from start to finish
- Phased upgrades and updates that fit your operating budget
- Improved process control resulting in lower operating costs
- Extended life cycle for your existing DC drive systems, delaying a move to AC drive technology until the time is right

Proven MV Drives Control Technology

Power Electronics Controller (PECe)

- Standard industrial PC
- Intel-based chipset
- VXWorks operating system
- IEC1131 Compliant Function block
- Deterministic Ethernet
- 5 x 10/100 Ethernet ports
- 1.2 to 2.5 GHz
- 60°C ambient
- Fanless operation
- Two or four PCI slots allows Profibus, Profinet, Reflective memory, CaNbus, Modbus, EGD, etc.

Field I/O

- Modular construction
- Digital inputs/outputs ... 24 VDC
- Analog inputs/outputs ... +/- 10 VDC
- Fast deterministic EtherCat interface from PECe

Touchscreen for operator control and maintenance

Replacing antiquated meters and push buttons with modern touchscreen controls will immediately improve your ability to operate and maintain your MV drives' controls.

P80i Toolbox – Drive Commissioning and Maintenance

- High-speed trending
 - Unlimited signals per trending
 - Up to 3,000 samples per signal
 - Limited only by PECe memory capacity tool capabilities
 - Configure trend (trigger, period, variables to be recorded)
 - Trend can be set to be uploaded to a compact flash drive
 - Upload records from the drive
 - Display records in a trend
 - Display 'live' or 'logged' data

Power Interface Board (PIBe)

- 24 copper or 32 fiber optic outputs to power devices
 - 8 digital inputs
 - 4 digital outputs
 - 8 analog inputs
 - 4 analog outputs
 - 2 current transformer inputs
- Capable of 60 V, 10 amp outputs to power devices
- One encoder input

Remote Monitoring System Architecture

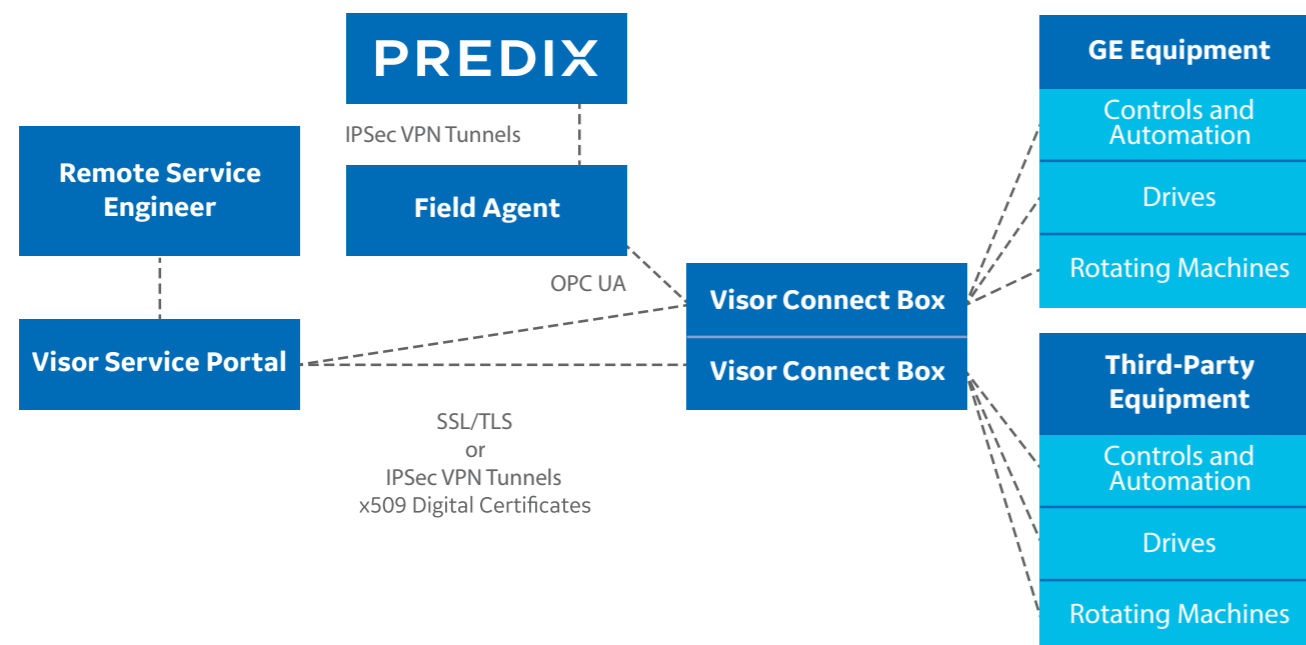

Spare Power Stack and Stack Extractor for MV Drives

Help Minimize Risk of Failures and Improve Equipment Uptime

Despite every effort to maintain your drives, unforeseen outages are inevitable. Ensuring equipment availability is a priority and having the right spares is essential for maintenance purposes. Spare stacks and specialized tools are the key to quick recovery in the event of a drive failure. However, knowing which spares to keep in stock and where to source others can be a challenge. This is where GE can help.

MV Drive Power Stacks

Spare power stacks for MV7000 and SD7000 series medium voltage drives are available direct from our factory in Villebon. They include a full range of DFE, IGBT, IEGT, thyristor, diode and chopper types. A full list of part numbers and special promotions for multiple buys is available on request.

Easy Repairs Using GE's Stack Extractor

Power stacks are key components of drives and play a crucial role in keeping them running at the required power. It's often difficult to carry out inspections or replacements, which require time and effort. There are also safety risks during the manual disassembly of each stack. As a full-scale OEM with engineering expertise, GE has designed a semi-electric, fully retractable and easy-to-use stack extractor for use with any MV7 or similar drive. The extraction tool speeds up repairs and improves overall recovery time in case of drive failure.

Power Stack Spare and Tool Kit Bundle

The offer includes:

- Spare stacks meeting standard factory serial routine tests to help minimize downtime
- Semi-electric, robust, easy-to use extractor tool that helps reduce MTTR to two hours
- Repair services for damaged stacks to help you reduce cost and extend the life of existing stacks

Reduce Lead Times with Spare Stacks

Holding spare power stacks in stock is crucial for keeping your equipment running. This is because lead times for their procurement can be long. In addition, unavailability of spares in your inventory may lead to extended downtime in the event of a failure.

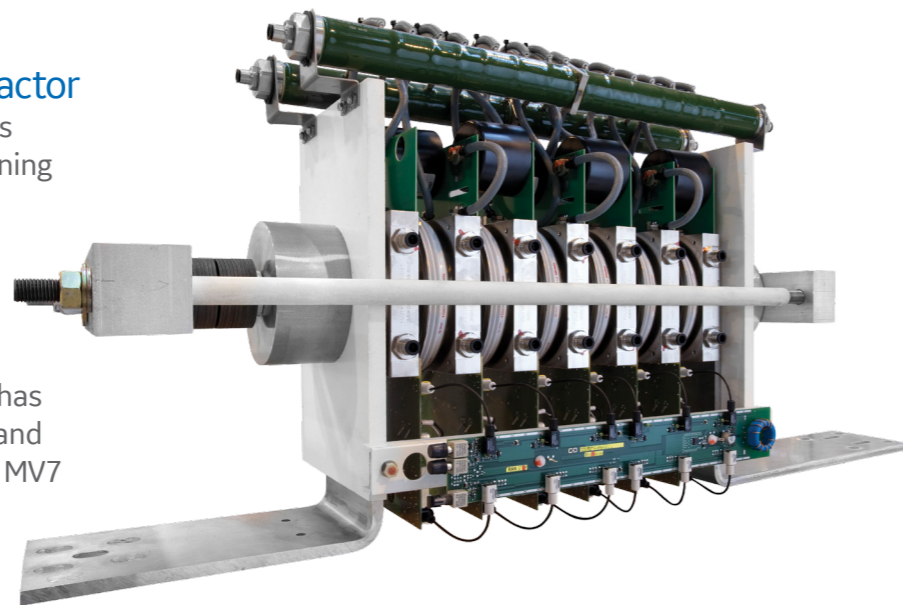

Maintenance Toolkit for MV7000 and SD7000 Drives

Ensure Equipment Availability and Improve Uptime

Unplanned equipment outages cause significant loss of productivity and revenue. Ensuring equipment, spares and toolkit availability on site can help you recover quickly in the event of an outage. Even in cases involving planned outages, it is vital to get equipment up and running again as fast as possible.

Accelerate Your Drives' Maintenance

For quick and easy maintenance of your cooling systems, GE offers two types of compact, easy-to-use maintenance toolkits, corresponding to MV7000 and SD7000 drives. With a single toolkit, you can carry out maintenance on all drives belonging to the same series (MV7000 or SD7000), irrespective of the application in which they are being used.

These toolkits can be used without any additional components, with the compact design being easily handled and stored at any temperature or humidity rate.

Benefit From GE's Industry and Application Expertise

Most production processes run without interruption. By moving from reactive to proactive services and maintenance models, we can help you to elevate operations to the next level, improving productivity and asset performance.

Our focus on service keeps us actively engaged, both when things are going right and when they are going wrong. With a comprehensive global network of experts, GE is uniquely positioned to provide the knowledge, experience and skills for your full range of industrial service requirements. We can help to maximize productivity, protect assets and support you with optimizing operations and maintenance costs.

MV7000 Drive Cooling System Maintenance Kit

- Designed to support any MV7 cooling system maintenance
- Easy cooling system maintenance for pipes and connections
- Compatible with all MV7 with either 3.3 kV or 6.6 kV, AFE or DFE option, 12 or 24 pulses
- Compatible with legacy and new MV drives which include UPONOR piping technology
- Kit supports the four different sizes in the cooling system: 8mm, 10mm, 12mm, and 18mm. It includes male and female plugs and internal sockets for those four sizes. The length of the four pipes allows you to change any pipe in the converter
- Compact and easy to store
- No preparation required
- Meets all aspects of Health, Safety and Environment

MV7000 & SD7000 Drives Cooling System Maintenance Kit

- Designed to support any MV7 and SD7000 cooling system maintenance
- Easy cooling system maintenance for pipes and connections
- Compatible with either 3.3 kV or 6.6 kV, AFE or DFE option, 12 or 24 pulses
- Kit supports the three main different sizes in the cooling system 3/8", 1/2" and 3/4" and also composed by plugs for those three sizes
- Sufficient length of the three pipes sizes for any connection requirement
- Compact and easy to store
- No preparation required
- Meets all aspects of health, safety and environment

Automatic Voltage Regulators Replacement or Retrofit

Regulator systems from GE provide excitation current up to 35 A with high accuracy, exceptional control flexibility and powerful diagnostics. All in a cost-effective, easy-to-use package.

Applying Deep Expertise

At GE, we not only build Automatic Voltage Regulators (AVR), we offer support throughout the product life cycle. Our field experts are positioned to provide full support for EX2100e AVRs and perform upgrades with minimal system disruption. As a full-scale OEM with fleet knowledge and deep engineering expertise, we're your partner of choice for retrofits and replacing AVRs nearing the end of their life cycle.

Low-Risk Solution With a Simple Upgrade Path and Full Support

A reliable and cost-effective upgrade by our experts can help to:

- Improve reliability
- Enhance performance
- Reduce risk of unplanned outages
- Increase availability and help maximize productivity
- Improve serviceability
- Help ensure longevity of product life

In the last 40 years, GE has supplied more than 6,000 thyristor and regulator systems in over 70 countries. The EX2100e is GE's fourth-generation digital excitation control system and our advanced regulator for steam, gas or hydro generators – both for new and retrofit units.

EX2100e Excitation Control Regulator Systems Include:

- Industry-leading control limiter with a protection function to help maximize generator performance
- Flexible architecture, modern networks and versatile software suite to simplify operations and integration with plant level controls
- Powerful diagnostics and control simulator to support rapid installation, tuning of control constants and training
- Advanced algorithms and the latest control technology designed to improve performance
- Product life cycle support able to perform conversions, modernizations and upgrades
- 24/7 technical support to help resolve issues as quickly as possible, ensuring minimum downtime

Excitation Control Upgrade

Product Features

MOUNTINGS	
S	Open Panel (for customer's enclosures) 23"H x 22"W x 10"D
S	NEMA1 Wall-Mounted Integral Enclosure 29"H x 22"W x 10"D
O	Free Standing Cubicle NEMA1 (IP21) 90"H x 30"W x 24"D
O	Free Standing Cubicle NEMA4 (IP54) 90"H x 30"W x 24"D
POWER CONVERTER	
S	Isolating Transformer 120/240VAC, 1PH, 50/60Hz
O	Primary 480 or 575 VAC
S	Incoming HRC Fuses
S	Thyristor Converter, 1 Phase, (1-20Amp), NRX
O	Control Constant Voltage Transformer
PLC CONTROL	
S	GE Intelligent Platforms Rx3i PLC
DIGITAL REGULATING FUNCTIONS	
S	Field Current Regulator (Optional Autotracking)
S	Max/Min Exciter Field Current Clamps
S	Non-Volatile Setpoint and Ramp
S	VAr/PF Regulator (Optional Autotracking)
O	Bus Voltage Support
O	Multi Motor VAr Control
S	Redundant PF Feedback System
START/ RUN CONTROL	
S	Initiated by Starter Interlock
S	Field Application by Timer
S	Field Application By Motor Speed (If Motor Sensor Fitted)
S	Clutch/Loading Interlocking
O	Reduced Voltage Start Control (1)

Product Features

ROTOR PROTECTION	
S	Slipguard (PF) Pullout Function (Digital)
S	Incomplete Sequence
S	Under/Over Excitation (Independent of Feedback)
S	Stall Protection Using Motor Speed Sensor (if Fitted)
O	Brushless Exciter Diode Monitoring
OPERATOR INTERFACE	
S	Integral Field Analog Ammeter
S	6" Quick Panel HMI Interface
O	12" Quick Panel high-contrast HMI Interface
S	Mode and Reference Adjusting, Display of Key Variables
S	Event Log with Date/time Stamp
S	Lockable Access to Parameter Adjustment
O	Analog Power Factor Meter and/or Field Voltmeter
O	GE Multilin SR469 Motor Protection Relay
REMOTE INTERFACE	
S	Ethernet TCP/IP, Modbus TCP
S	Web server for remote viewing of HMI parameters
O	GENius, RS485 Modbus RTU, DeviceNet or Profibus

S = STANDARD. O = OPERATIONAL. (1) = CONSULT FACTORY.



Free Standing Cubicle Version (Shown with optional Multilin SR469, PF meter, and voltmeter)

Rotating Machines Health Check

Reduce Risk

We know that any unplanned downtime can be expensive, with costs between \$3,000 and \$30,000 per hour. We also know that good maintenance reduces the risk of an outage. But just how good does this need to be? Maintaining machines can be expensive, so you don't want to do any more than is needed.

Equipment Health Checks

GE has designed, built and commissioned thousands of rotating machines. We continue to maintain many of them as part of a planned service cycle. When customers have an unplanned outage we help get them back on line as fast as possible. However, prevention is better than cure, so we also offer equipment 'maintenance strategy reviews' or "health checks." These can identify potential issues and help shape an OEM-designed maintenance plan to help avoid any unwelcome outages.

Maintenance Strategy

After the healthcheck, customers benefit from an OEM-designed, knowledge-based, best practice maintenance strategy that is specific to their rotating machines. This will help to avoid unplanned outages and minimize maintenance costs.

Health Check Features

Our field service expertise covers both GE and non-GE equipment. We carry out non-invasive equipment inspection while it's operating, and work with you to understand historic maintenance, environmental conditions, budget constraints, operational constraints and business imperatives.

During the Health Check We:

- Identify safety critical issues – bringing them to your attention immediately and proposing a resolution.
- Prioritize the dispatch of parts needed to resolve such issues. If necessary, the field engineer will remain or return to site to supervise the solution.
- Identify operational-critical issues, reductions in performance or critical items affecting reliability—bringing these to your attention.

After the Health Check We:

- Recommend a maintenance plan, based on our experience of thousands of similar machines.
- Suggest an OEM-designed plan to help avoid unplanned outages.
- Identify critical spare parts, providing a list of spares you should consider holding and suggest details of obsolete parts you may wish to replace.
- Put forward upgrade packages appropriate to your equipment and circumstances.

Rotating Machines Inspection

To ensure efficient operational continuity, it's important to schedule regular rotating machine maintenance with a frequency that reflects the operating conditions. For example, dirty conditions and open ventilated machines will require more regular inspections and cleaning than closed circuit machines in a clean environment.

We offer a variety of cost-effective inspection programs, for both GE and non-GE equipment, to ensure proactive life cycle planning. Our expert team can share with you an in-depth understanding of maintenance requirements, helping you avoid unplanned downtime while improving performance and lifespan.

Tailored to Your Needs

Building on our OEM expertise and field service experience, we provide a selection of inspection programs tailored to your operating conditions.

These thorough programs are designed to provide early detection of issues throughout the rotating machine's lifetime. This helps to avoid potential failures and prevent unplanned downtime. As our programs are adapted to operating conditions, they help minimize the number and duration of required outages, while effectively assessing unit reliability and suggesting maintenance actions.



Expert Support

As an equipment manufacturer, we have extensive experience in maintaining a global installed base of rotating machines. Our team of field service engineers can undertake inspections, troubleshoot and repair on site. Plus, through the engineers, tools and equipment at GE factories, we can repair or overhaul your equipment in house.

Our OEM rotating machines support service is provided by the engineers who designed the equipment. This means they can advise you on the most appropriate OEM-designed upgrades to help manage obsolescence and maintain original equipment performance, as well as adding new functionality or controls.

This expertise is not only limited to our own products. Our rotating machines service business covers both GE and non-GE equipment, enabling us to deliver state-of-the-art services for most machinery in the industry.

Safety and Training

GE is committed to ensuring the highest levels of safety for both its employees and customers – training your maintenance teams to help you to carry out inspections safely and competently.

Rotating Machines Modification and Upgrade Services

Having supplied thousands of machines over more than a century, we appreciate that equipment is a considerable investment and one that can exceed its initial expected lifespan. Keeping machines well maintained in accordance with the recommended service schedule will prolong their life. However, you may also want:

- Improved efficiency, lower fuel burn or reduced operating cost
- More power or lower starting requirements
- Increased reactive power to cater for demand-side loading
- Greater noise attenuation or revised code compliance
- A revised mix of attributes for altered circumstances

If you are considering replacing your unit, we go beyond expectations – proposing re-engineered solutions that use cutting-edge technology.

Modification or Upgrade?

Drawing on our bank of design information, drawings and specifications – alongside our manufacturer’s insight – GE can assist in maintaining your equipment. We also support the re-engineering of components or assemblies. This improves performance and can be more economical than a complete machine replacement.

Assembly	Typical Options	Benefits
Rotor	Integral Tip rotor Salient/solid pole Laminated rotor Squirrel cage	Inherently robust High power density High efficiency Asynchronous choice
Stator	Vented stator Pin vented stator	Older technology Increased cooling/efficiency
Frame	Retain	Avoid unnecessary cost

It may even be possible to provide you with a revised temperature class of machine alongside rating changes

Rotors, Stators and Machines

The main parts of an electrical rotating machine are the rotor, stator and frame. We can explore fully engineered solutions for replacing one or more of these components, restoring or even enhancing the available efficiency and power.

At GE, we use an integrated system approach that combines engineering expertise with our incomparable knowledge of rotating machines. For both replacement machines and upgrades, we support you from start to finish. This can include project management, application engineering, full design engineering, testing and technical direction of installation, commissioning and spare parts. As our experience spans most industries and sectors, we’re able to understand your application, appreciate your challenges and help you get the highest performance possible from your equipment.

Phased Upgrades – Low Risk, Cost-Effective

If you’ve installed GE equipment, our engineered solutions enable a phased upgrade to the next generation of technology without having to replace complete machines. Benefits of phased upgrades may include:

- Lower total install costs by reducing the expense of purchasing, installing and commissioning an entirely new machine or system
- Reduced operating expenses and increased equipment reliability
- Extended life and mitigated obsolescence through phased installation and greater spare parts availability
- Reduced system operating downtime
- Planned upgrades or modifications that mitigate unplanned outages

Rotor Modification/Upgrade

Rotor assembly replacement is the more straightforward option. At a planned time, we can substitute a replacement rotor for the existing one, using specialized rotor extraction equipment. The main machine bearings can also be easily renewed at this time.

A replacement modern rotor can help to provide higher efficiency (particularly important in ‘rotor limited’ machines), a higher power/reactive power rating or even revised inertia. Recent technological design improvements may even allow a switch of rotor type from solid to laminated, or vice versa.

Stator Modification/Upgrade

Stators possibly have the greatest influence on overall machine performance. A replacement stator made using current technology can help to provide greater efficiency, revised output power – or both. The stator replacement can be on its own or combined with a rotor replacement to deliver added benefits. Technological improvements in stator materials, insulating systems and the use of the GE-patented pin vent TM cooling scheme all offer advantages over older designs.

We can fit new coils to existing stators. However, a complete new stator assembly may enhance the machine and minimize downtime, improving the return on investment.

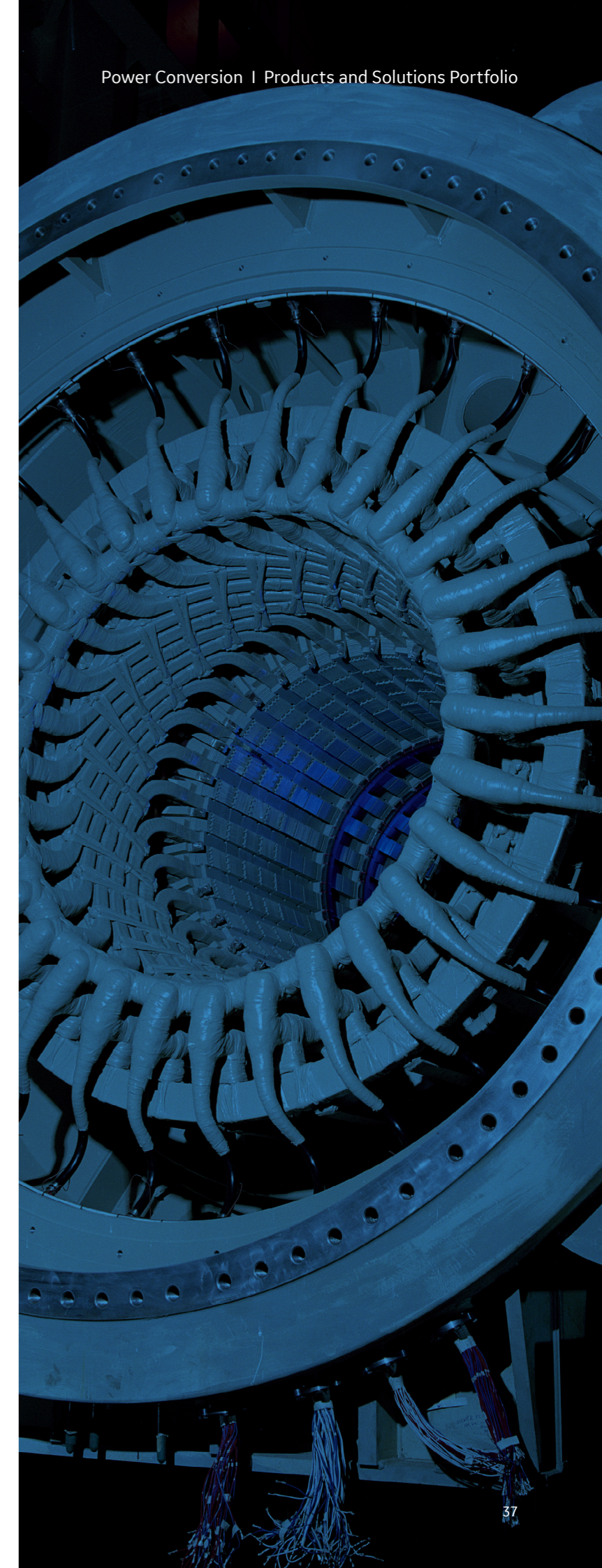

Induction Motors Spare Parts

Minimize Failure Impacts and Improve Equipment Uptime

Parts failure and unplanned outages are inevitable for electrical rotating machinery. Ensuring high equipment availability is a key priority, with access to the right spare parts essential for quick recovery. Knowing which spares to keep in stock and where to source others is therefore critical.

Deep Expertise and the GE Advantage

As an OEM with over 125 years of engineering expertise, we provide top-quality spare and replacement parts. We also offer the right advice when you need it. At GE, we pride ourselves on our exceptional level of customer service. It's of a standard that only the experts who designed, manufactured, installed, commissioned and continue to maintain these motors can provide.

Local Presence Supported by a Global Organization

Our advanced technology Global Customer Service and Support Center is available round the clock, every day of the year. Thanks to distribution centers located across the globe that carry extensive inventory for our products, we can support your part replacement needs at any time.

Reduce Lead Times, Stock Critical Spare Parts

Holding the right spares in stock is critical for keeping your equipment running. This is because lead times can be long for procuring parts and the unavailability of critical spares in your inventory may lead to extended downtime in the event of a failure.

We can help you to identify common parts across multiple machines and determine which spares to carry. We classify motor spare parts into three main categories, based on criticality:

- **HIGH Criticality**
Components including the stator, rotor and exciter, without which the machine will fail and cease to operate, resulting in downtime of up to six months,
plus:
Components including bearings, seals, fan motors, pressurization units and brushes, without which the machine will fail and cease to operate, resulting in downtime of up to 15 weeks.
- **MEDIUM Criticality**
Components including cooler batteries and fan motors, without which the machine continues to operate at a reduced load. Associated downtime is up to 15 weeks.
- **LOW Criticality**
Components including space heaters, air and bearing probes and leakage detectors, which have no immediate effect on the machine. However, there is risk of failure of system protection. Associated downtime is up to 10 weeks.

Key Oil & Gas References

Sub-Segment	Application	Country	Main Scope of Supply
Upstream	FPSO	Angola	5 * VSDS for the high-pressure compressor units, incl. Step-down transformer, MV7000 drives, induction motors (9.61 MW/6 kV/1,717 rpm/4 poles) 1 * VSDS for low-pressure compressor unit incl. Step-down transformer, MV7000 drive, induction motor (4.89 MW/6 kV/1,717 rpm/4 poles)
	Offshore platform	Denmark	7 * VSDS incl. high-speed application and three generator sets, with two 16MW/8,000rpm induction motors offshore
	CPF & FPSO	Australia	6 * Alpha Synchronous Generators (39 MVA/11 kV/50 Hz) driven by Gas Turbines
Midstream	Shale gas and gas processing	Canada	10 * VSDS incl. Transformers, MV7000 drives, electric motors, e-Houses
	Gas transportation	Germany	4 * ICL incl. high speed induction motors (13.6 MW/8,280 rpm) and MV7000 drives
	Pipeline	Alaska	SGT400 driven Alpha Synchronous Generators (17 MVA/13.8 kV/60 Hz) packaging close-coupled epicyclic gearboxes on the generator frame
Downstream	Refinery	USA	1 * synchronous motor (33 MW/36 poles/200 rpm/soft starter)
	Refinery	Singapore	1 * VSDS for turbine replacement incl. high-speed motor (11,280 rpm/ 2,565 kW/Oil bearing) and MV7306 drive
	Refinery	Uzbekistan	2 * Alpha Synchronous Generators (53 MVA/10 kV/50 Hz) driven by Steam Turbines
LNG	eLNG	USA	10 * complete electrical systems incl. Step down transformer 96 MVA, Frequency converter LCI (80 MW/2x11 kV), 2pT Synchronous motor (75 MW/3,000 rpm), e-House
	Starter helper	Russia	7 * complete electrical systems incl. Step down transformer 32 MVA, Frequency converter LCI (35 MW/2x4.4 kV), 2 pT Synchronous motor (24 MW/3,600 rpm)
	Starter helper	USA	2 * complete electrical systems incl. AN Transformer (13.8 kV/6x1.85 kV/50 & 60 Hz), Frequency converter VSI (27 MW/9 kV), Two-pole induction motors (20 MW/3,600 rpm each)



For more information on GE Power Conversion's Oil and Gas Solutions, please contact your local sales representative.

APAC

Tel: +65 62 207022

CHINA

Tel: +86 216 198 2600

FRANCE

Tel: +33 3 83384000

Tel: +33 1 77312000

GERMANY

Tel: +49 3076220

LATAM

Tel: +55 313268 8000

NORTH AMERICA

Tel: +1 4129670765

UNITED KINGDOM

Tel: +44 1788 563563

gepowerconversion.com